

TYPE	OUTPUT		POLE	TIME RATING	VOLTAGE V	Hz	SYN.SPEED R.P.M
	HP.	kW.					
AEHGTK	800	597	4	CONT.	2300/4160	60	1800

TOTALLY ENCLOSED FAN-COOLED TYPE, SQUIRREL-CAGE ROTOR

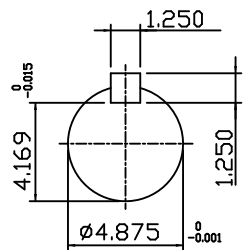
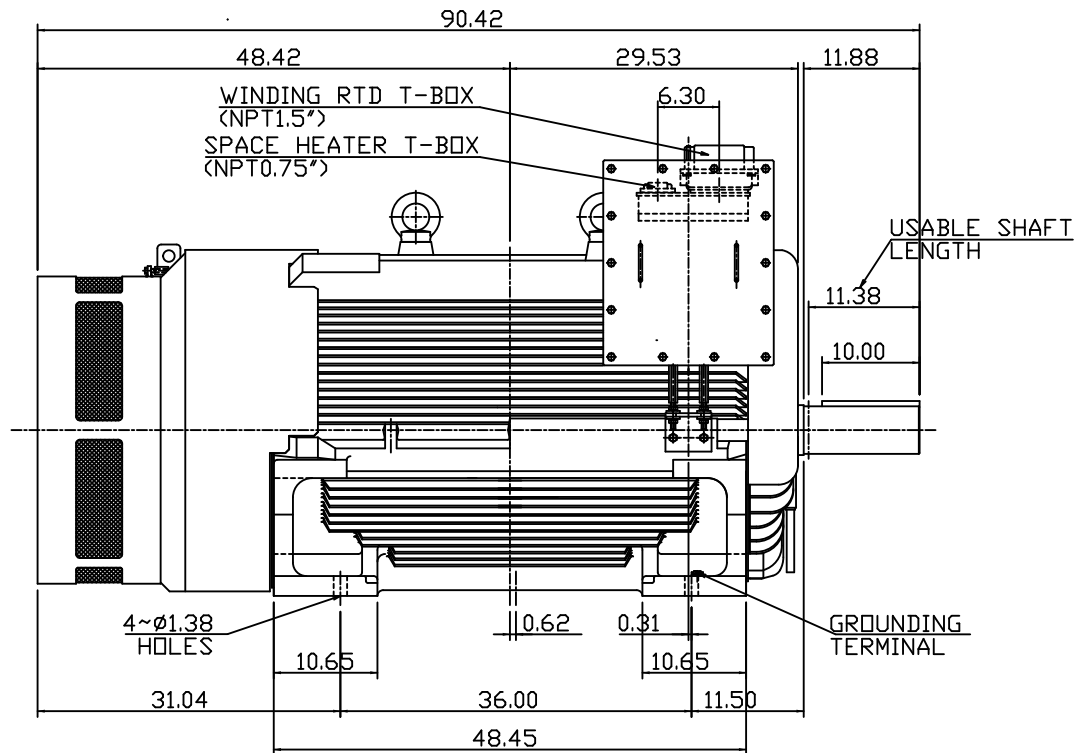
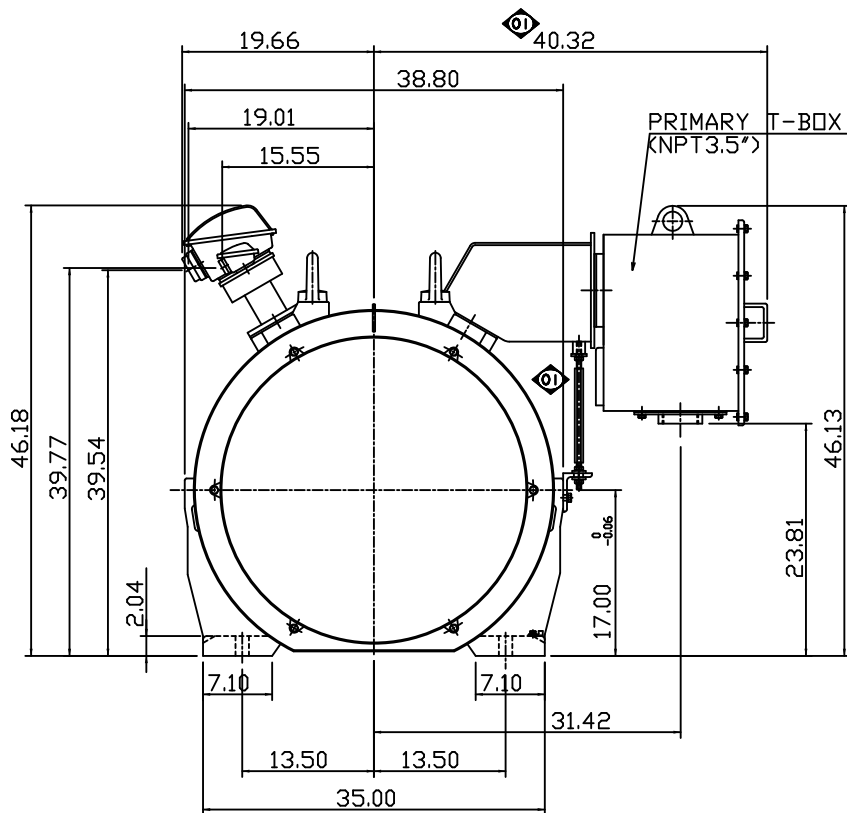

SHAFT END
(ENLARGED VIEW)

- NOTE:
1. DIMENSIONS IN INCH
 2. FRAME NO. 6808B
 3. F CLASS INSULATION, S.F.1.15
 4. FOR DIRECT FLEXIBLE COUPLING
 5. ENCLOSURE: IP54
 6. BEARING SIZE: DRIVE-END 6326
OPP. DRIVE-END 6322
 7. WITH SPACE HEATER & WINDING RTD
 8. MOTOR APPROX. WEIGHT: 8500LBS

DATE	OCT. 29, 2014	OUTLINE DIMENSIONS
CATALOG #	KG8004	3-PHASE INDUCTION MOTOR
DWN.	Y.DU	AUG-29-2011
CHKD.	H.HUANG	AUG-29-2011
APPD.	B.LIN	AUG-29-2011
TEC Westinghouse		DWG NO. REV: 01 4A040G955